

Promat

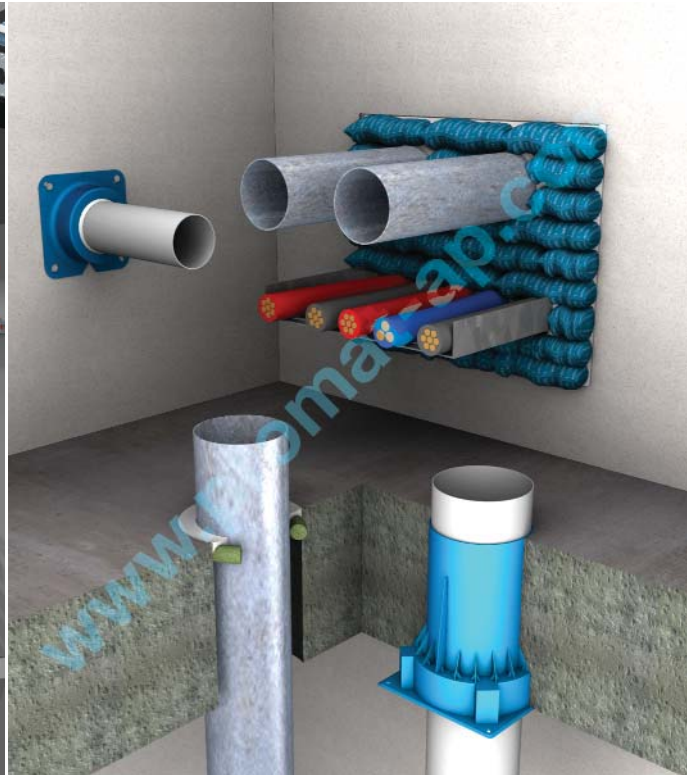

PROMASEAL® Retrofit Collars For Plastic Pipes Fire Protection





Introduction

Fire resisting compartments are created to inhibit and prevent fire and smoke from spreading within building structures. This also creates a parallel threat as most concealed cavities between fire resisting walls and floors are interlinked. The importance of sealing gaps in this type of construction is thus vital to the integrity of compartmentation systems and their ability to prevent fatalities and loss of property. Such gaps are typically service penetrations through walls and floors but also include gaps created for structural movement and gaps due to poor workmanship.

These unfortunate but inevitable facts of construction industry life have led in recent years to the increased development of effective solutions to seal gaps wherever they occur. Intumex is a leading worldwide solution provider.

It should be noted that every service passing through fire resistant building elements reacts in a different way to fire, heat, smoke and fumes. There is no single solution, product or system that will protect all services.

Services must be tested in accordance with the test method outlined in appropriate standards. Tests are generally carried out in accordance with the General Principles of BS476: Part 20: 1987 or EN1366: Part 3 and 4 covering both penetration seals and linear joint seals respectively. In addition, many countries use the Australian Standard AS4072: Part 1: 2005 (Components for the Protection of Openings in Fire-Resistant Separating Elements), which specifies testing in accordance with the test method set out in AS1530: Part 4: 2005. It is also important to note that although all of the above test methods can be considered similar, there are some major differences which affect particular applications. Please see following pages for comparative test method/data.

Failure Criteria

Failure is measured in terms of integrity and insulation. Stability (or Structural Adequacy) is not recorded for service penetrations except those which are required to be loadbearing, e.g. PROMASTOP® Cement.

Integrity failure occurs when cracks, holes or openings allow the passage of flames or hot gases. Furthermore, integrity failure is measured in different ways, depending on which standard is used.

For example, AS1530: Part 4: 2005 measures integrity failure as flaming on the unexposed face for a time greater than 10 seconds and by using a cotton pad, held against any gap, to see if the cotton pad ignites within 10 seconds. Other standards measure integrity failure using the same criteria but also using additional methods such as:

- using a cotton pad, held against any gap, to see if the cotton pad ignites within 10 seconds; or
- if the gap is equal to or greater than 150mm x 6mm; or
- if a 25mm diameter probe can pass through a gap.

Insulation failure occurs when the temperature rise on the unexposed surface of the service, on the unexposed face of the building element 25mm from the penetration or on the seal itself exceeds 180°C. Insulation failure is inevitable on many metal service penetrations and is often waived as a failure criterion by local building regulations. Under such circumstances it is essential that combustibles be kept at least 100mm clear of these services at the point of penetration.

The PROMASEAL® and PROMASTOP® range of products were introduced to complement Promat's wide range of fire protection board systems.

Due to the ongoing development of fire test standards for this product, penetration seals and similar applications, only brief details can be provided at the time of this press. For detailed information and advice on the current range of PROMASEAL® and PROMASTOP® range of products, please contact Promat.

IMPORTANT: Because of the diversity of applications and the on-going test programme, the above and the following notes in this section are of a general nature only and it is essential to confirm that the system specified or being installed is approved for use. Always contact Promat to confirm the specification is correct prior to usage.

	British Standards BS476: Part 20: 1987	European Standards EN1366: Part 3: 2004/ EN1366: Part 4: 2006	Australian Standards AS4072: Part 1: 2005/ AS1530: Part 4: 2005	United States Standards ASTM E814: 1997/ UL1479: 1998
Orientation	Requires representative specimen in both orientations. For asymmetrical specimens, a test should be conducted from each side using separate specimens.	Representative or standard service configurations tested both in horizontal and vertical orientation.	Requires full size or representative specimen and testing in both horizontal and vertical orientation if intended for use in both orientation. Provide standard test configurations.	UL requires both orientations must be tested unless it can be demonstrated that testing in a single orientation does not affect the results. ASTM does not specify but there are differences in temperature and pressure measurements for the two orientations so that, by default, both would be required.
Test sample	Does not specify projection distances of through penetrating elements. The end conditions of pipes should reflect the "as installed" conditions.	The services shall be installed so that they extend 500mm on each side of the supporting construction, of which at least 300mm shall extend beyond the extremities of the sealing system. No part of the service shall be <200mm from the furnace wall or another service. Movement joint seals shall be installed in uniform design cross-sectional area and to maximum length that can be accommodated by separating test element. For non-movement joint seals a shorter length may be used subject to a minimum of 900mm.	The ends of the services shall be sealed on the exposed side of the furnace, to simulate normal extension through compartment. If the end condition of the the unexposed side is unspecified, it shall be left unsealed. The penetrating element shall extend 500mm into the furnace and 2000mm outside the furnace for plastic pipes, all other elements are 500mm inside and outside the furnace.	The penetrating item should extend into the furnace by 300mm and out of it by 910mm. The end of the item on the exposed face is capped, but uncapped on the unexposed side, unless is it to represent a closed system in which case it may be capped. The periphery of the specimen should not to be closer than 1.5 the thickness of the assembly, or 300mm to the furnace edge, whichever is greater.
Conditioning	Materials shall, at time of test, be at a condition approximating the state of strength and moisture content that would be expected in normal service.	The test specimens shall not be tested until both strength and moisture content approximate values the service expects to attain.	The test specimens shall not be tested until both strength and moisture content approximate values the service expects to attain.	Prior to fire testing, each test sample and test assembly is to be conditioned, if necessary, to provide a moisture condition likely to exist in similarly constructed buildings.
Protection of assembly and sample	Ambient temperature should be within 5-35°C prior to heating period, and temperature measurements on the unexposed face must be in draught-free conditions.	Provide reference for test frames and the ambient condition must be 20°C(±10°C) at the commencement of test. During testing, the laboratory temperature shall not decrease >5°C or increase by >20°C for all insulated separating elements while they still satisfy the insulation criterion.	Not specified except that the initial furnace temperature must be not less than 10°C and not more than 40°C.	The testing equipment and test sample are to be protected from any condition of wind or weather that might influence the test results (i.e. ambient temperature at the time of testing must be within 10-32°C while the velocity of air across the sample must not exceed 1.3m per second).
Pressure differential	At mid height of vertical systems, the pressure differential is 15Pa, and the same pressure 100mm below horizontal systems.	For a vertical system with height <1000mm, the pressure differential should be 15±2Pa. If the height >1000mm, pressure differential should be 20±2Pa at the top of the specimen. In this case penetrations should be included in the zone where the pressure is >10Pa. For a horizontal system, the pressure differential should be 20±2Pa at 100±10mm under the supporting construction.	Not less than 20Pa at notional 100mm below the soffit height of horizontal element or at a level with lowest point of the penetration seal of a vertical element it should be 15Pa±3.	Except for the first 10 minutes of the test, the furnace pressure shall be at least 2.5Pa greater than the pressure on the unexposed side of the following locations: a) Wall – at lowest elevation of the test specimen; b) Floors – at the location of the pressure probes. Test sponsor may also specify a unique pressure condition in which case it must be maintained throughout the duration of the test, excluding the first 10 minutes, within 20% of the specification.

	British Standards BS476: Part 20: 1987	European Standards EN1366: Part 3: 2004/ EN1366: Part 4: 2006	Australian Standards AS4072: Part 1: 2005/ AS1530: Part 4: 2005	United States Standards ASTM E814: 1997/ UL1479: 1998
Integrity	<ul style="list-style-type: none"> a) Cotton pad test; b) Gap gauge; c) Sustained flaming of more than 10 seconds. 	<ul style="list-style-type: none"> a) Cotton pad test is generally performed. For penetration seal tests the use of reduced size cotton pad is permitted if necessary. b) Whilst gap gauge is used for measurement in general test specimens, it shall not be used for evaluation of penetration and linear joint seals tests. c) Sustained flaming. 	<p>Failed when:</p> <ul style="list-style-type: none"> a) Cotton pad test, or b) Flaming takes place at the unexposed face of the specimen for a period exceeding 10 seconds. 	<p>Shall not permit the passage of flame through-out the fire test, or water through the hose stream test. Mandatory for all ratings in both standards, i.e. ASTM and UL.</p>
Insulation	<p>The insulation of the specimen is judged to have failed if the temperature on the unexposed side and on penetrations reaches 180°C above the initial temperature.</p>	<p>The insulation of the specimen is judged to have failed if the temperature on the unexposed side and on penetrations reaches 180°C (K) above its initial temperature.</p>	<p>The criteria for failure of insulation is if the temperature of any of the thermocouples on the unexposed side reaches 180°C above the initial temperature.</p>	<p>Shall not permit the passage of flame through the fire test, or water through the hose stream test or allow the temperature to increase by 180°C on the unexposed side. Mandatory for T rating in both standards.</p>
Hose stream test	<p>No specification.</p>	<p>No specification.</p>	<p>No specification.</p>	<p>For both F and T ratings, a duplicate specimen is subjected to a fire exposure test for period half of the desired rating but not more than 60 minutes. Immediately after the fire exposure, the specimen shall be subject to the hose stream test. Same test assembly can be used for both tests but must take place within 10 minutes from the completion of the fire test.</p>
Specification	<ul style="list-style-type: none"> a) Integrity; b) Insulation; c) Loadbearing capacity where applicable. 	<ul style="list-style-type: none"> a) Integrity; b) Gap gauge (not applicable for penetration and linear joints seal tests); c) Cotton pad; d) Insulation; e) Insulation area 2 (if the test element incorporating two discrete areas of different thermal insulation). 	<p>AS1530: Part 4 states results to be expressed in:</p> <ul style="list-style-type: none"> a) Integrity; b) Insulation. 	<p>Specified in terms of F rating which require a hose stream test, and T rating which does not require a hose stream test, measures the insulation. UL have an additional L rating for air-leakage.</p>
Reporting	<ul style="list-style-type: none"> a) Temperature data from all specified critical thermocouple; b) A detailed description of all penetrating services; c) A detailed description of the test construction. 	<p>In addition to requirements of EN1363: Part 1, the following are necessary for penetration seal tests:</p> <ul style="list-style-type: none"> a) For tests on pipes, statement of the pipe end configuration (capped or uncapped); b) For cables, the cable dimensions; c) For metallic pipes, the pipe dimensions; d) For unsupported seals, the maximum area free of services; e) Whether multiple penetrations have been tested in a single test construction. <p>For linear joint seal test, the following shall be included:</p> <ul style="list-style-type: none"> a) Full description of any procedure used to induce relative movement of the seal faces; b) Orientation of test specimen; c) The limits of the range of nominal widths and the movement capability successfully tested; d) Full description of the splicing method(s) used. 	<p>In addition to the requirements of AS1530.3, some of the requirements in AS1530.3: Part 4 are:</p> <ul style="list-style-type: none"> a) Temperature data from all specified critical thermocouple; b) A detailed description of all penetrating services; c) A detailed description of the test construction. 	<p>Report must have:</p> <ul style="list-style-type: none"> a) Description of assembly and materials; b) Relative humidities; c) Temperature recordings; d) The achieved rating; e) Location of pressure probes and differential pressure of the test; f) Record of all observations; g) Correction factor.
Commentary	<p>For positions of thermocouples and other items not specified in this standard, laboratories refer to the EN standard.</p>	<p>These standards are now in effect for use within the industry.</p>	<p>Comprehensive and simple standard configurations, as well as details on permissible variations.</p>	<p>UL also have an addition L rating which is to be reported as the largest leakage rate determined from the air leakage test.</p>

Which System(s) To Use

As penetrations can occur in various building elements, there are a number of important criteria that require consideration in determining the appropriate type of sealing system to be used, simplified in the following chart.

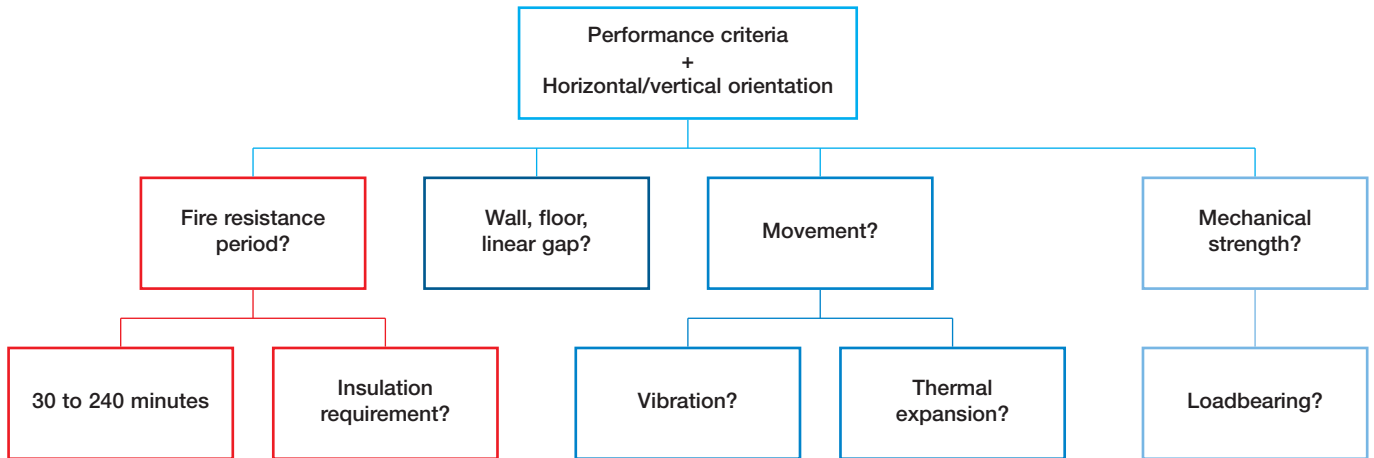

Limitations of Use

- Size of opening
- Penetration services
- Flexibility of seal(s)
- Smoke or gas lightness
- Ambient conditions
- Design life
- Frequency of change to services
- Parent construction (type of substrate)

Special Considerations

In instances where electrical and mechanical services are involved, the selection of penetration sealing system also require the following additional elements to be carefully considered.

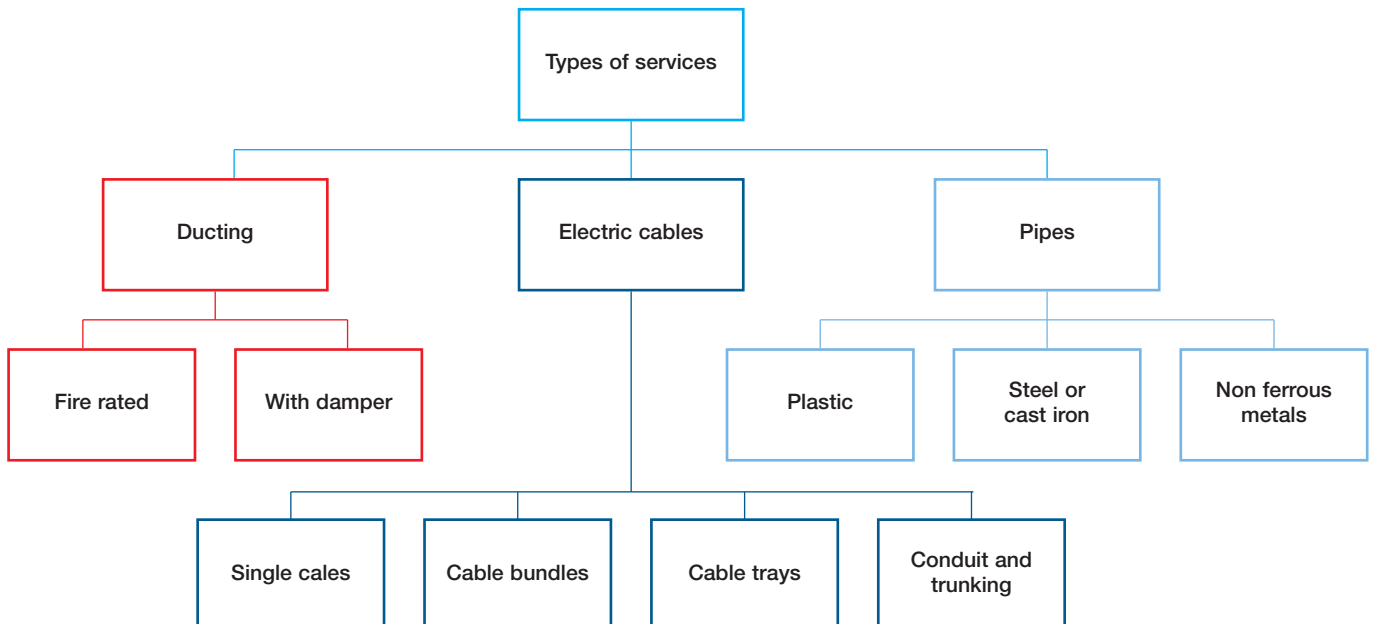

Compatibility Considerations

- Intumescent systems in lightweight constructions
- Rigid seals in "dynamic" barriers
- Large spans and thermal expansion
- Smoke or toxicity in populated zones
- Dusty or friable materials in clean room applications

It has been shown that plastic pipes penetrating compartment walls or floors or other fire barriers represent potential for fire to pass from one compartment to another when the plastic burns and melts away. All building regulations specify that the fire resistance of the separating element of construction between compartments must not be impaired by services that pass through them.

In general, methods of maintaining acceptable fire resistance will vary between countries and regulatory authorities. The most common method of fire resistance, however, is to install fire collars around plastic pipes, penetrating separating elements.

All fire collars are designed to prevent the spread of fire where plastic pipes, cables and other services penetrate fire resistant elements of construction, maintaining the Fire Resistance Level (FRL) of the element.

Virtually all fire collars consist of intumescent compounds which, exposed to fire or sufficient heat, expand under pressure to set and seal the penetrations. The unique and patented design of PROMASEAL® and PROMASTOP® collars contain no asbestos, fibres or solvents. They are unaffected by water and most atmospheric conditions

In the case of plastic pipe penetrations, it should be clearly noted that particular care must be exercised when accepting assessments or test reports. Abundant research and empirical data indicates that different types of plastic behave in very different ways under actual fire conditions. Indeed, realistic test data reflects the following:

1. The Type of Plastic

Building materials made of different type of plastics, such as high density polyethylene (HDPE), polyvinyl chloride (PVC), unplasticised polyvinyl chloride (uPVC), polyethylene (PE), polypropylene (PP), acrylonitrile butadiene styrene (ABS) etc, are commonly used in modern buildings. These plastics soften, melt or burn at different rates and temperatures. Fire stopping products, particularly collars, have to be shown capable of coping with all variables, including the full range of diameters, in all different plastic thicknesses, in both horizontal and vertical orientations.

2. Pipe Diameters

The bigger the pipe the more difficult it is to seal, mainly due to the rate of the intumescent reaction for the fire stopping material to seal the openings.

3. The Orientation of Pipe (to Wall or Floor)

Pipes tested in a floor will not necessarily behave in the same manner when tested in a wall and the reverse equally applies.

4. The Wall Thickness of Pipe

Thin wall pipes collapse fast and fire collars have to react swiftly to close the opening. Thick walled pipes collapse slowly and fire collars have to retain sufficient expanded intumescent product to seal openings over a longer period of exposure.

5. Pipe End Conditions During Test

Pipes that have been fire tested with both the end inside and the end outside of the test furnace and capped (sealed) must only be protected with these fire collars when the end conditions on site are similar.

It is generally accepted that if a pipe is tested with the end inside the furnace capped, and the end outside the furnace uncapped, that this test would cover storm waste, sewage and water supply. If pipes are tested with both ends capped, this would represent a less onerous position, e.g. pipes that have taps or valves or water traps in line.

The Promat range of fire collars are purpose made of plastic (cast-in) painted steel shells (retrofit) with integral mounting points, containing a specially formulated intumescent material. They prevent the passage of fire through gaps in compartment walls and floors caused by the collapse and/or melting of combustible services in the event of fire. It is essential that the correct fire collars are specified and that they are installed in accordance with Promat instructions.

As a general rule there are THREE (3) types of collars:

Surface Mounted (Retrofit) Type

Surface mounted collars (also known as retrofit collars) are fixed around the plastic pipe, onto the surface of a building element. For floor slabs this is on the underside of the slab. For walls, they are generally placed on both sides to protect against fire exposure from either direction.

If it can be shown that the fire can only come from one side, then the fire collar may be placed on the fire risk side of the wall provided that test data is available to prove the application achieves the required fire resistance. PROMASTOP® UniCollar® (with the code of UC) and PROMASEAL® fire collars (with the code of CFC, FC or FCS) can all be used as retrofit collars.

Insert Type

Insert collars are placed around the pipes, within the thickness of the wall or floor. Generally, only one collar is required to protect from either direction for walls.

PROMASEAL® Wall Collars (with code FCW) can be used as insert wall collars. These collars sit within the cavity of lightweight partitions, ideal for use where space is at a premium. This is particularly useful for work in shafts or any area where access for installation is restricted to one side.

PROMASTOP® UniCollar® may also be used on some types of pipe for these applications.

Cast-in Type

Cast-in collars are used only in floor slabs and are placed into position, on the formwork, before a slab is poured. This method means accurate setting out of all plumbing work is vital.

PROMASEAL® fire collars (with the code of Hi-Blu, Green or PSS), can be used as cast-in collars. For use with floor waste, there are two special collars, PROMASEAL® cast-in type collar (FWS) and retrofit type collar (FWR).

Recommended Specification

Where appropriate, the specified plastics penetrations through floor/wall openings should be properly fire stopped using a PROMASTOP®/PROMASEAL® collar capable of providing fire resistance of -/240/-, -/240/240, -/180/180 or -/120/120 or as specified in the appropriate regulations or by the relevant regulatory body, when tested and assessed in accordance with AS1530: Part 4 or BS476: Part 20: 1987 as applicable. From 2008 the BCA no longer allows the waiving of insulation criteria for plastic pipe penetrations as a Deemed to Satisfy solution. Such waiving is now treated as an alternate solution. Installation of any fire stopping product should be carried out according to the manufacturer's recommendations. Please consult Promat for further details.

IMPORTANT: Because of the diversity of applications and Promat's on-going test programme, the above information and the following notes in this section are of a general nature only and it is essential to confirm that the fire collar specified or being installed is approved for use on the size and type of plastic pipe, the orientation and type of service. Always contact Promat to confirm the specification is correct.



PROMASEAL® FC Retrofit Collar (square base)

PROMASEAL® FC Retrofit Collars are multi-purpose collars designed for use with concrete slabs, masonry and lightweight walls and lined ceilings.

These split type collars can be retrofitted where necessary. They are available in a range of sizes to suit plastic pipes up to 315mm *outside diameter**. The collars have been tested for up to 240 minutes FRL in accordance with the criteria of AS1530: Part 4 and AS4072: Part 1 with various types and sizes of plastic pipe.

PROMASEAL® FC Retrofit Collars above 200mm have a circular base, not square as are smaller diameters.

**It should be noted that the FRL for some of the larger collars is restricted in some types of application, therefore before using any collar with a diameter in excess of 110mm, please consult Promat to ensure the proposed application and requisite FRL can be achieved.*

PROMASEAL® FCS Retrofit Collar (circular base)

PROMASEAL® FCS Retrofit Collars are designed to be fitted around installed pipes that pass through floor slabs and have been tested with uPVC, HDPE and ABS pipes in accordance with the criteria of AS1530: Part 4 and AS4072: Part 1, on pipes up to 150mm diameter.

The larger opening within the collars will accommodate pipes (and UPVC pipe fittings) that have differing outside diameters.

The collars should be unclipped, placed around the pipe, re-clipped and pushed tight to the substrate.

PROMASEAL® FCS Retrofit Collars have been tested for FRL of up to 240 minutes in floors with uPVC pipes and ABS pipes, and 180 minutes in floors with HDPE pipe (except 100mm which is tested to 240 minutes), and on floors and walls for Post Mix drink lines for 120 minutes.

Both PROMASEAL® FC and FCS Retrofit Collars are split to enable them to be retrofitted or relocated when necessary.

Installation Guide

PROMASEAL® FC/FCS Retrofit Collar For pipes up to 315mm/162mm diameter with mortar

PROMASEAL® FC and FCS Retrofit Collars are to be fixed to the under side of the floor slabs. Ensure all fixing points are used. Maximum diameters of pipes for FC type is up to 315mm and FCS type up to 162mm.

For FRL of up to 240 minutes with pipes up to 225mm outside diameter, the collars are bolted to the soffit of a floor slab using 38mm steel expanding anchors or steel wedge anchors. Fixings for collars up to 162mm diameter may be 25mm steel sleeve anchors. Pipes with 315mm outside diameter can achieve up to 120 minutes fire resistance in this application.

FC type collars greater than 250mm are for un-vented pipes.

PROMASEAL® AN Acrylic Sealant may be applied around the pipe on the top side if a water seal is required. If there is a possibility of pipe movement occurring that will cause cracks or fissures in the seal between the pipe and mortar mix, it is advisable to seal around the pipe with PROMASEAL® AN Acrylic Sealant to prevent cold smoke leakage. This, however is not required for the fire resistance to be achieved.

If there is a gap greater than 12mm between the pipe and cored hole, backfill with PROMASEAL® Mortar. For gaps less than 12mm, seal with PROMASEAL® AN Acrylic Sealant. See illustration on [page 8](#) for example.

PROMASEAL® FC Retrofit Collar

For uPVC pipes up to 110mm diameter

For FRL of up to 120 minutes in masonry or lightweight walls for uPVC pipes up to 110mm* diameter.

For FRL of up to 120 minutes on calcium silicate, masonry and plasterboard walls for pipes up to 110mm outside diameter. Minimum wall thickness is 116mm. The collars must be on both faces for lightweight timber or steel framed walls.

Fix the collar to a masonry wall using 50mm Tapcon “Hi Lo”, course thread screws suitable for masonry fixing or use steel masonry anchors. Fix the collars with No.10 x 40mm laminating screws to lightweight timber or steel framed walls.

*For specific installation for collars over 110mm diameter and single-sided application, please contact Promat.

See illustration on [page 8](#) for example.

PROMASEAL® FC Retrofit Collar

For pipes up to 162mm diameter

FC PROMASEAL® Retrofit Collars can be cast into floor slabs for uPVC pipes up to 162mm diameter for FRL of up to 120 minutes. The collar should be installed to the soffit side of the floor. See PROMASEAL® Hi-Blu Collar and PROMASEAL® Green Cast-in Collar for general cast in applications. See PROMASEAL® FWS and FWR Collars for floor waste applications.

Nail the collar to the formwork. Cut a length of the pipe and push it firmly into the collar until it touches the formwork. Ensure the pipe is cut square so that the pipe sits on the formwork level.

It should be noted that this collar type is not designed to take a pipe fitting. For such an application use a Hi-Blu or Green collar.

See illustration on [page 9](#) for example.

PROMASEAL® FC Retrofit Collar

For pipes up to 162mm diameter with mortar

FC PROMASEAL® Retrofit Collars can also be installed into a cored hole with PROMASEAL® Mortar used to back fill for a flush fit. This application is for uPVC pipes up to 162mm diameter.

For FRL up to 120 minutes with pipes up to 162mm outside diameter, bolted to the soffit of a floor slab using 25mm steel expanding anchors. Ensure all fixing points are used. Back fill the hole in the slab with PROMASEAL® Mortar or commercial grade mortar mix.

See illustration on [page 9](#) for example.

PROMASEAL® FC Retrofit Collar

For pipes up to 162mm diameter with acrylic sealant on ceiling

FC PROMASEAL® Retrofit Collars can be installed to uPVC and HDPE pipes in 60 or 120 minutes fire resistant ceilings. Use PROMASEAL® AN Acrylic Sealant to seal edges, provide additional framing to support the collar. This application is for pipes up to 162mm diameter.

60 and 120 minutes applications with pipes up to 162mm outside diameter, screw fixed to the framing grid to the underside of a ceiling system that provides a similar fire rating. The gap between the pipe and the opening through the ceiling liner board must be no more than 15mm and should be filled with PROMASEAL® AN Acrylic Sealant to the full depth of the lining board. Specific details are available for various ceiling systems on request.

See illustration on [page 9](#) for example.

IMPORTANT: Always check with the Promat Technical Department to ensure the collar type under consideration is appropriate for the type, diameter, and thickness of the plastic pipe and the application and orientation are covered by relevant certification.



TECHNICAL DATA

For FRL up to -/240/240, insulation criteria will vary depending on type and sizes of the pipes, and the type of penetrating elements.

- 1 PROMASEAL® FC Retrofit Collar (square base)
- 2 PROMASEAL® FCS Retrofit Collar (circular base)
- 3 Fixing with suitable anchor, i.e. steel expanding fasteners or laminating screws.
- 4 Plastic piping, e.g. HDPE, uPVC etc.

- 5 Masonry or concrete floor slab/wall
- 6 Existing fire resistant wall, constructed from masonry or concrete, timber or steel framed lightweight partition.
- 7 PROMASEAL® AN Acrylic Sealant to act as a seal against the passage of cold smoke (not required for fire performance if the movement of cold smoke is not being considered)

NOTE: FCS collars allow for fittings and couplings to go within the collar depth, thus allowing pipes to fit closer to the substrate.

Dimensions Guide

PROMASEAL® FC Retrofit Collar (square base)

Code no.	Pipe nom. (mm)	Body (mm)			Flange (mm)
		H	D1	D2	D3
FC 40	40	43	45	77	112
FC 50	50	43	58	90	125
FC 65	65	43	71	103	138
FC 80	80	43	85	123	158
FC 100	100	53	112	150	185
FC 125	125	63	127	165	197
FC 150	150	73	162	200	235
FC 250*	250	120	254	316	380 Ø
FC 300*	300	160	318	402	466 Ø

*FC with circular base

PROMASEAL® FCS Retrofit Collar (circular base) – For floors only

Code no.	uPVC pipe nom. (mm)	HDPE pipe nom. (mm)	ABS pipe nom. (mm)	Body (mm)			Flange (mm)
				H	D1	D2	D3
FCS 40	40	50	40	43	56	84	131
FCS 50	50	56	50	43	70	98	145
FCS 65	65	75	–	43	84	113	161
FCS 80	80	90	80	43	98	138	186
FCS 100	100	100	100	53	127	167	214
FCS 150	150	150	–	70	172	212	259

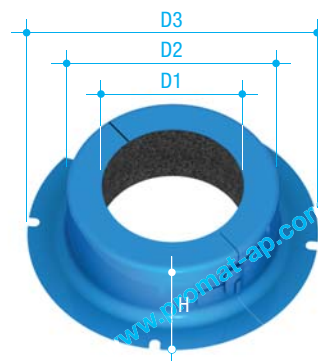
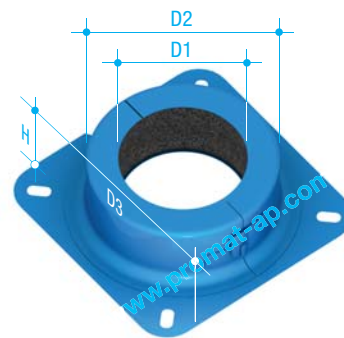

Dimensions of PROMASEAL® Retrofit Collar, FC (square) and FCS (circular) types.



PROMASEAL® FC Retrofit Collar
For pipes up to 162mm diameter

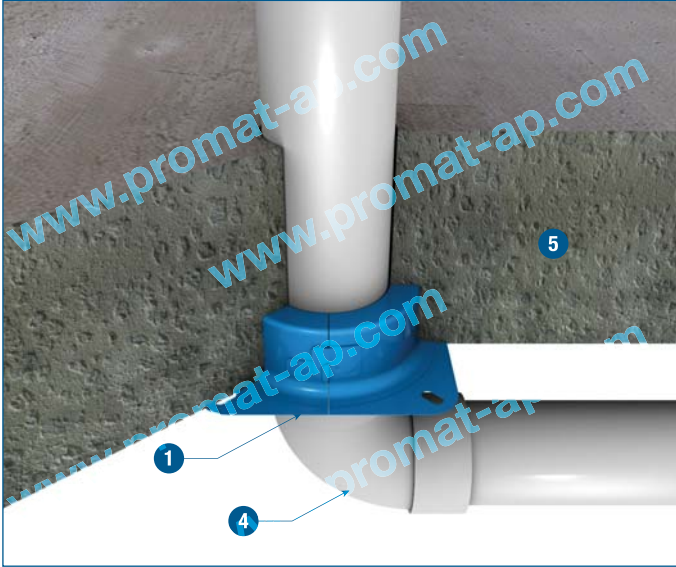

PROMASEAL® FC Retrofit Collar (>200mm diameter with circular base)
For pipes up to 315mm diameter

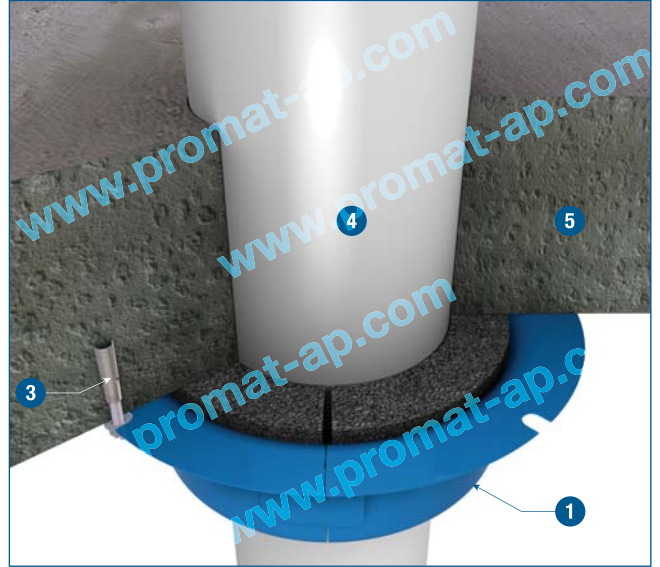

PROMASEAL® FC Retrofit Collar
For pipes up to 162mm diameter with mortar backfill



PROMASEAL® FCS Retrofit Collar
For pipes up to 162mm diameter



PROMASEAL® FC Retrofit Collar
For pipes up to 162mm diameter with acrylic sealant on ceiling

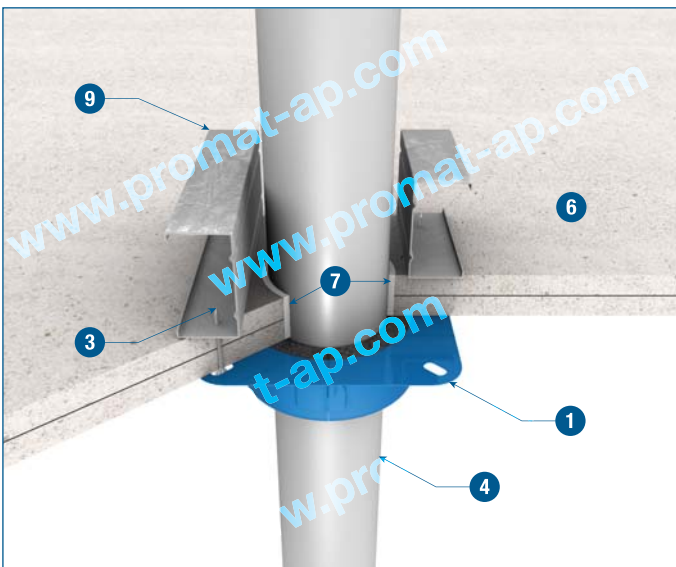

TECHNICAL DATA

For FRL up to -/240/240, insulation criteria will vary depending on type and sizes of the pipes, and the type of penetrating elements.

- 1 PROMASEAL® FC Retrofit Collar (square base)
- 2 PROMASEAL® FCS Retrofit Collar (circular base)
- 3 Fixing with suitable anchor, i.e. steel expanding fasteners or laminating screws.
- 4 Plastic piping, e.g. HDPE, uPVC etc.
- 5 Masonry or concrete floor slab
- 6 Existing fire resistant ceiling, constructed from lightweight boards
- 7 PROMASEAL® AN Acrylic Sealant to act as a seal against the passage of cold smoke (not required for fire performance if the movement of cold smoke is not being considered)
- 8 PROMASEAL® Mortar
- 9 Steel backing channels at fixing position

For latest information of the Promat Asia Pacific organisation, please refer to www.promat-ap.com

ASIA PACIFIC HEADQUARTERS

Promat International (Asia Pacific) Ltd.

Unit 19-02-01, Level 2 PNB Damansara
No.19 Lorong Dungun, Damansara Heights
50490 Kuala Lumpur
MALAYSIA
Tel: +60 (3) 2095 5111
Fax: +60 (3) 2095 6111
Email: info@promat-ap.com

AUSTRALIA

Promat Australia Pty. Ltd.

1 Scotland Road
Mile End South, SA 5031
Tel: 1800 PROMAT (776 628)
Fax: +61 (8) 8352 1014
Email: mail@promat.com.au

New South Wales Office

Promat Australia Pty. Ltd.

Unit 1, 175 Briens Road
Northmead, NSW 2152
Tel: 1800 PROMAT (776 628)
Fax: +61 (2) 9630 0258
Email: mail@promat.com.au

Victoria Office

Promat Australia Pty. Ltd.

Suite 205, 198 Harbour Esplanade
Docklands, VIC 3008
Tel: 1800 PROMAT (776 628)
Fax: 1800 334 598
Email: mail@promat.com.au

Queensland Office

Promat Australia Pty. Ltd.

1/68 Lisgar Street
Virginia, QLD 4014
Tel: 1800 011 376
Fax: 1800 334 598
Email: mail@promat.com.au

CHINA

Promat China Ltd.

Room 506, Block A, Qi Lin Plaza
13-35 Pan Fu Road
510180 Guangzhou
Tel: +86 (20) 8136 1167
Fax: +86 (20) 8136 1372
Email: info@promat.com.cn

Beijing Office

Promat North China

(Division of Promat China Ltd.)

Room 1507 Building 5, SOHO Xiandaicheng
No.88 Jianguo Road, Chaoyang District
100022 Beijing
Tel: +86 (10) 8589 1254
Fax: +86 (10) 8589 2904
Email: info@promat.com.cn

For Promat International groups worldwide:

www.promat-international.com

- The technical data provided in this publication is based on mean values prevalent at press time and is thus subject to fluctuation. It should not be regarded as a guarantee to system performance.
- All data contained herein conforms to and frequently surpasses generally accepted fire protection standards recognised by most professional fire science practitioners and regulatory authorities worldwide. The same general principle is equally applicable to all Promat products and systems. Promat has access to a considerable body of test authentication data and this can be provided on a complimentary basis upon request. It should be noted however that this publication replaces all previous editions in its entirety. Any form of reproduction by any means – manual, electronic, digital or otherwise – is strictly prohibited and subject to prior approval in writing from Promat. All rights related or connected to the Promat logo, Promat registered trademarks, featured illustrations, written information and technical reports in this publication are the sole, exclusive and copyright property of Promat and its legal partner companies.

HONG KONG

Promat International (Asia Pacific) Ltd.

Room 1010, C.C. Wu Building
302-308 Hennessy Road
Wanchai
Tel: +852 2836 3692
Fax: +852 2834 4313
Email: apromath@promat.com.hk

INDIA

Promat International (Asia Pacific) Ltd.

(India Representative Office)

610-611, Ansal Imperial Tower
C-Block, Community Centre
Naraina Vihar, Naraina
110028 New Delhi
Tel: +91 (11) 2577 8413
Fax: +91 (11) 2577 8414
Email: info-india@promat-asia.com

Bangalore Office

Promat International (Asia Pacific) Ltd.

(India Representative Office)

Cabin No.BC-9 & BC-10
Oculus Workspaces, No.66/1, 2nd Floor
Coles Road, Frazer Town
560005 Bangalore
Tel: +91 (80) 4031 4151
Fax: +91 (80) 4125 2135
Email: info-india@promat-asia.com

Mumbai Office

Promat International (Asia Pacific) Ltd.

(India Representative Office)

Stylus Serviced Offices
Ground Floor, Velocity
Phase 1, Logitech Park
Andheri Kurla Road, Andheri East
400072 Mumbai
Tel: +91 (22) 4376 4567
Fax: +91 (22) 4376 4568
Email: info-india@promat-asia.com

MALAYSIA

Promat (Malaysia) Sdn. Bhd.

Unit 19-02-01, Level 2 PNB Damansara
No.19 Lorong Dungun, Damansara Heights
50490 Kuala Lumpur
Tel: +60 (3) 2095 8555
Fax: +60 (3) 2095 2111
Email: info@promat.com.my

SINGAPORE

Promat Building System Pte. Ltd.

10 Science Park Road, #03-14 The Alpha,
Singapore Science Park II
Singapore 117684
Tel: +65 6776 7635
Fax: +65 6776 7624
Email: info@promat.com.sg

Your local Promat supplier

