

# FMI Fire Curtain

## Automatic Fire Curtain



### Data Sheet

#### THE PURPOSE OF A FIRE CURTAIN

The purpose of a fire curtain is to seal off an area to contain a fire and to prevent that fire from spreading to other areas. A fire curtain is used where, if there is a fire, it is necessary to create a temporary barrier within an opening. This barrier should not be visible at any other time.

#### THE COLT FMI FIRE CURTAIN

The Colt FMI Fire Curtain is low in weight and has minimal dimensions, which enables it to be installed easily in places with space constraints such as within a false ceiling.

The Colt FMI Fire Curtain automatically descends on receipt of a signal from the fire alarm panel or upon loss of power. Once this signal has been reset it automatically retracts.

#### CLASSIFICATION

The Colt FMI Fire Curtain has been tested to EN 1634-1 and is classified E60-C or E120-C in accordance with EN 13501-2:2007, thereby achieving an integrity rating for either 60 or 120 minutes.

"E" refers to integrity and "C" refers to a self-closing device (in other words, it unrolls in a gravity fail safe manner).

#### HOW THE COLT FMI FIRE CURTAIN WORKS

The fire curtain comprises a flexible heat resistant fabric which is impervious to smoke and hot gases, wound round a tube. The tube contains an electric motor which normally holds the curtain retracted at ceiling level.

Upon receiving a signal from the fire detection system or on loss of power the curtain automatically unwinds in a controlled, gravity failsafe manner. A heavy bottom bar is fitted to the bottom edge of the fabric to pull the curtain down, to keep the material taut and to provide a suitable finish when the curtain is retracted.

Metal side guides with a fabric retaining system provide a seal between the curtain fabric and the building. The fabric retaining system ensures that a seal is maintained and that the fabric does not spill out of the side guides under fire or other pressures.

#### FEATURES OF THE COLT FMI FIRE CURTAIN

- Third party testing and certification in accordance with EN 1634-1 (Warrington Fire)
- Two fire classification options: E 60 or E 120 integrity
- Certified guide rod system for side guides
- Heat stabilized coating for the fabric, with a stainless steel inlay for the E 120 option. Both E 60 and E 120 fabrics achieve the building classification A2 S1 d0 to EN 13501-2: 2007 ("Fire classification of construction products and building elements")
- Bottom bar with closure arrangement to ensure a tight seal even with uneven floors
- Expansion joints to allow for thermal movement incorporated into the design
- Removable access panel for headbox integral 48 V DC drive assembly which maintains a steady rate of gravity failsafe fall (approx. 0.12 m/s)
- A single 28 Nm overall torque drive
- Simple controls to receive external fire signals and for testing
- Supplied in partly pre-assembled form for fast installation.

Architectural Solutions

Climate Control

Smoke Control

Service and Maintenance

**Colt International Pty Ltd**

81 Market Street

Smithfield

NSW 2164

Tel: +61 2 9828 2500

Fax: +61 2 9609 6969

info@au.coltgroup.com

www.coltinfo.com.au

**VIC Office**

Tel: +613 9775 3841

**SA Office**

Tel: +618 8266 6040

**WA Office**

Tel: +618 9355 4213

**QLD Office**

Tel: +617 3458 2686

## CONTROLS

There are a variety of control arrangements. One option is a simple control box with switches and an indication lamp. Another option is for a smoke detector to be connected directly to this control box. A third option is for the local control box to be connected to the central fire detection system with a voltage free contact. Lights and sounders can also be supplied.

There is an option to include a battery back-up to retain the curtain in its retracted position for a set period if there is mains failure.

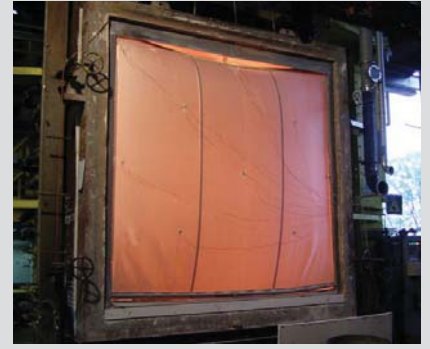

FMI Fire Curtain under test

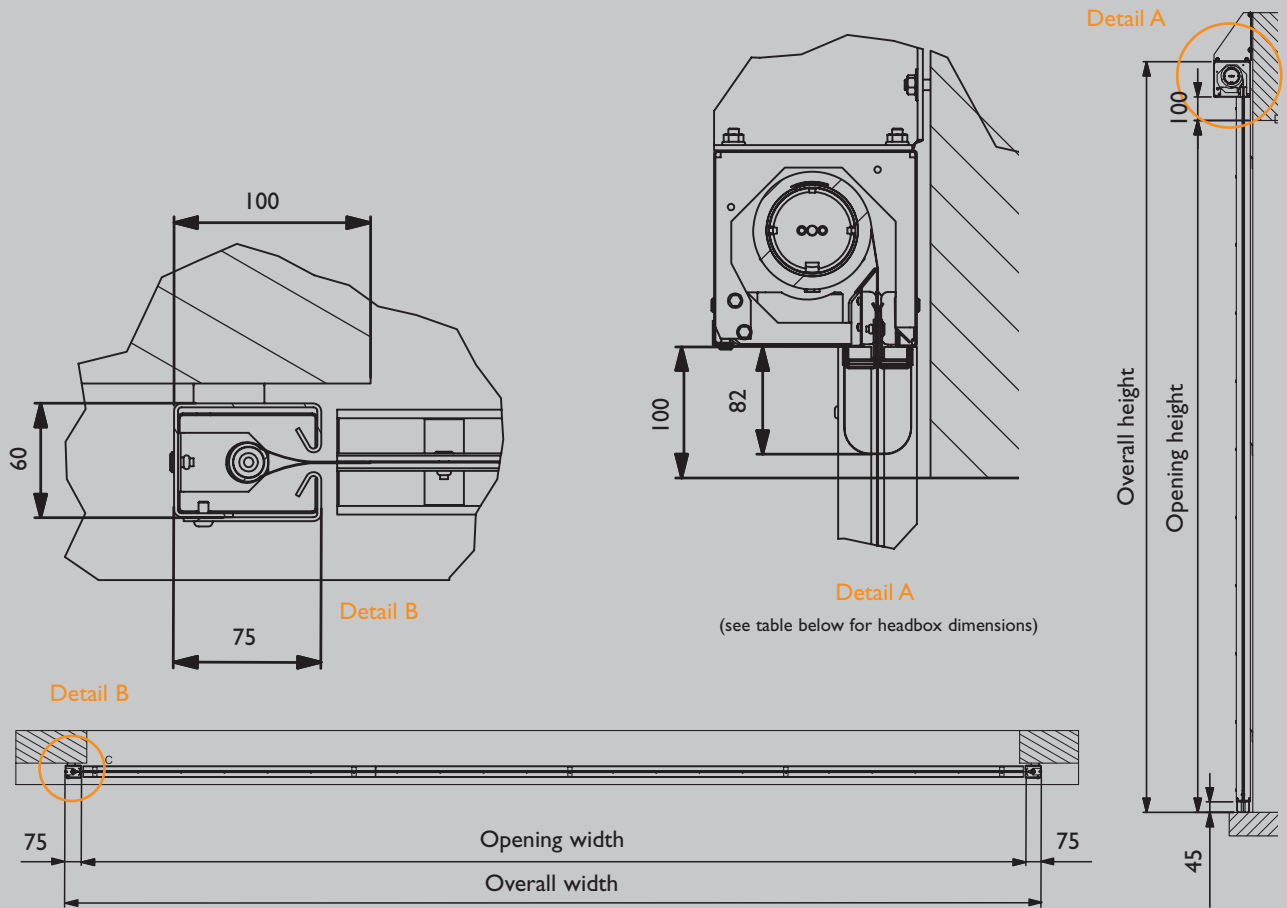

### MAXIMUM DIMENSIONS (mm)

Note that the standard tested unit is max. 3000 x 3000mm. Larger sizes may require an expert opinion in order to remain within the standard EN 13501-2 certification.

Curtain Type	Maximum Opening Width (mm)	Maximum Opening Drop (mm)	Headbox Dimensions (mm)
SI-E60 (single curtain, 60 minutes integrity*)	5000	5000	155 W x 150 H
SI-E120 (single curtain, 120 minutes integrity*)	5000	5000	180 W x 185 H
DH-E60 (multiple curtain, double horizontal headbox, 60 minutes integrity)	From 5000 up to any length	6000	250 W x 150 H
DH-E120 (multiple curtain, double horizontal headbox, 120 minutes integrity)	From 5000 up to any length	6000	300 W x 185 H
DV-E60 (multiple curtain, double vertical headbox, 60 minutes integrity)	From 5000 up to any length	6000	155 W x 250 H
DV-E120 (multiple curtain, double vertical headbox, 120 minutes integrity)	From 5000 up to any length	6000	180 W x 300 H

Minimum dimensions are 1000 x 1000 mm in each case.

\* In accordance with EN 1634-1.